



CONFIDENTIAL

THIS DOCUMENT AND INFORMATION CONTAINED HEREIN IS PROPRIETARY AND CONFIDENTIAL TO PRECOR STRENGTH INCORPORATED. RECIPIENTS OF THIS DOCUMENT AGREE THAT THIS DOCUMENT AND INFORMATION WILL NOT BE USED FOR ANY PURPOSE, REPRODUCED OR COPIED, OR DISCLOSED TO ANY THIRD PARTY, EITHER IN WHOLE OR IN PART WITHOUT PRIOR EXPRESS WRITTEN PERMISSION OF PRECOR STRENGTH, INCORPORATED.

PRECOR USA
PRECOR STRENGTH, INC.

28936 AVE WILLIAMS
VALENCIA, CA 91355
TELEPHONE: 661-362-0300

| | | |
|--------------------------------|----------|-----|
| SIGN IN BLUE OR BLACK INK ONLY | | |
| DRWN BY | 01.02.07 | MGP |
| DWG CHK | | |
| ENG | 01.02.07 | RSG |
| MPG ENG | | |
| CS | | |
| QA | | |
| ID | | |
| REG | | |

UNLESS OTHERWISE SPECIFIED:
DIMENSIONS ARE IN INCHES
TOLERANCES ARE:
LIN .X=±0.1 .XXX=±0.010
LIN .XX=±0.02 .XXXX=±0.0001
ANGULAR: ±1.0°
ALL DIMS AFTER PLATING
BREAK ALL SHARP EDGES
REMOVE ALL BURRS
ALL ANGLES & BENDS 90°
DWG PER ASME Y14.5M-1994
DO NOT SCALE DRAWING
ALL MACHINED SURFACES

PRODUCT:
STRENGTH

ASSEMBLY CONNECTION, 10.5, W/ 1 PULLEY HSG

| | | | |
|----------|-------------|--------|---|
| DWG. NO. | CW31868-402 | SUBREV | A |
|----------|-------------|--------|---|

| | | | | | |
|------|---|------|---|----|---|
| SIZE | C | PAGE | 1 | OF | 1 |
|------|---|------|---|----|---|

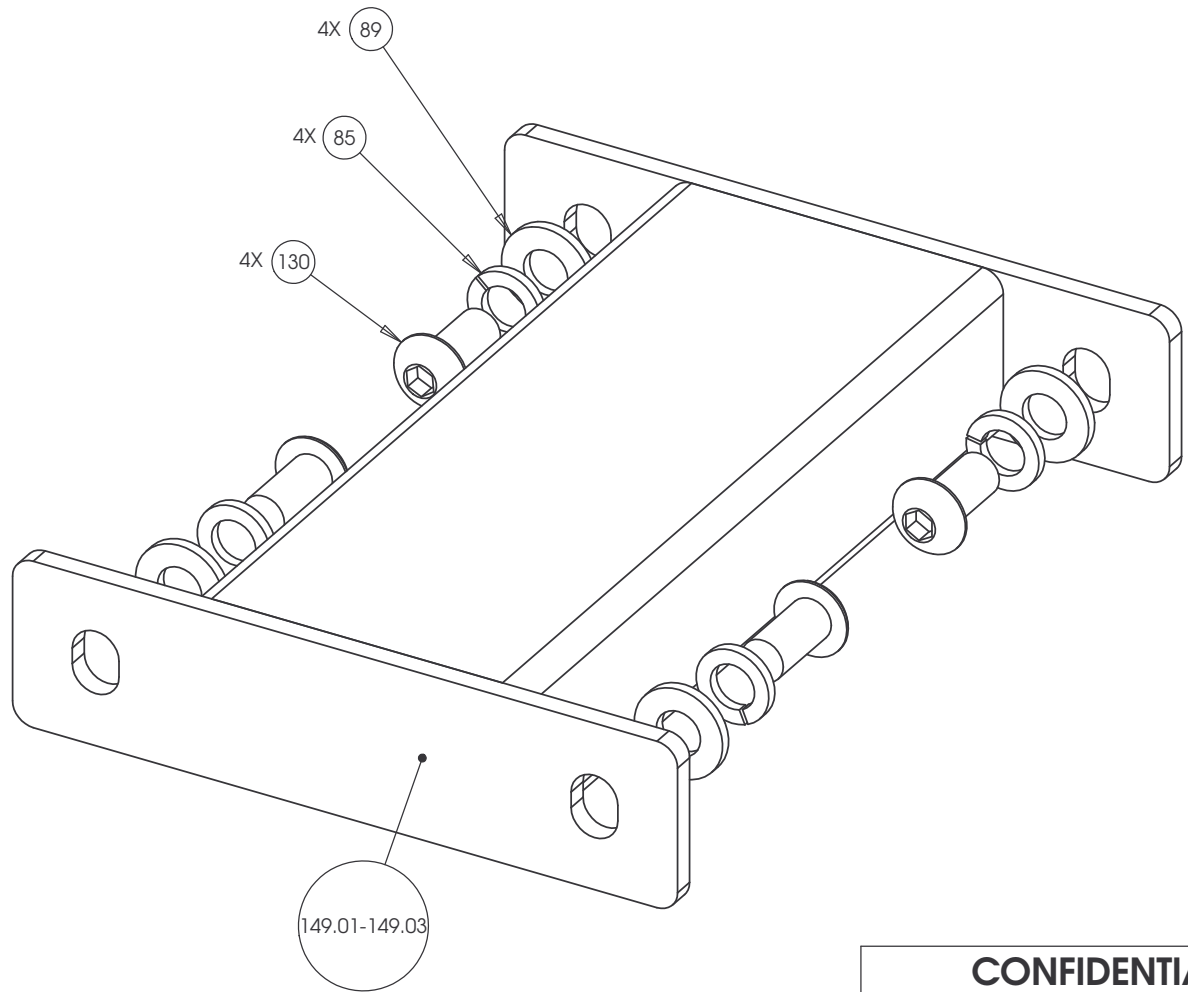

CONFIDENTIAL

THIS DOCUMENT AND INFORMATION CONTAINED HEREIN IS PROPRIETARY AND CONFIDENTIAL TO PRECOR STRENGTH INCORPORATED. RECIPIENTS OF THIS DOCUMENT AGREE THAT THIS DOCUMENT AND INFORMATION WILL NOT BE USED FOR ANY PURPOSE, REPRODUCED OR COPIED, OR DISCLOSED TO ANY THIRD PARTY, EITHER IN WHOLE OR IN PART WITHOUT PRIOR EXPRESS WRITTEN PERMISSION OF PRECOR STRENGTH, INCORPORATED.

PRECOR USA
PRECOR STRENGTH, INC.

28936 AVE WILLIAMS
VALENCIA, CA 91355
TELEPHONE: 661-362-0300

| | | | | | |
|--------------------------------|----------|-----|--|---------|------------------------------|
| SIGN IN BLUE OR BLACK INK ONLY | | | UNLESS OTHERWISE SPECIFIED: DIMENSIONS ARE IN INCHES | | PRODUCT: STRENGTH |
| DRWN BY | 08.15.06 | VLE | TOLERANCES ARE: LIN .X=±0.1 .XXX=±0.010 LIN .XX=±0.02 .XXXX=±0.0001 ANGULAR: ±1.0° | | |
| DWG CHK | | | ALL DIMS AFTER PLATING BREAK ALL SHARP EDGES REMOVE ALL BURRS ALL ANGLES & BENDS 90°* | | ASSEMBLY CONNECTION, 10.5 |
| ENG | 06.19.06 | RSG | DWG PER ASME Y14.5M-1994 DO NOT SCALE DRAWING ALL MACHINED SURFACES | | |
| MFG ENG | | | | | |
| CS | | | | | |
| QA | | | | | |
| ID | | | SIZE | PAGE OF | DWG. NO. |
| REG | | | C | 1 1 | CW31874-402 |
| | | | | | SUBREV A |

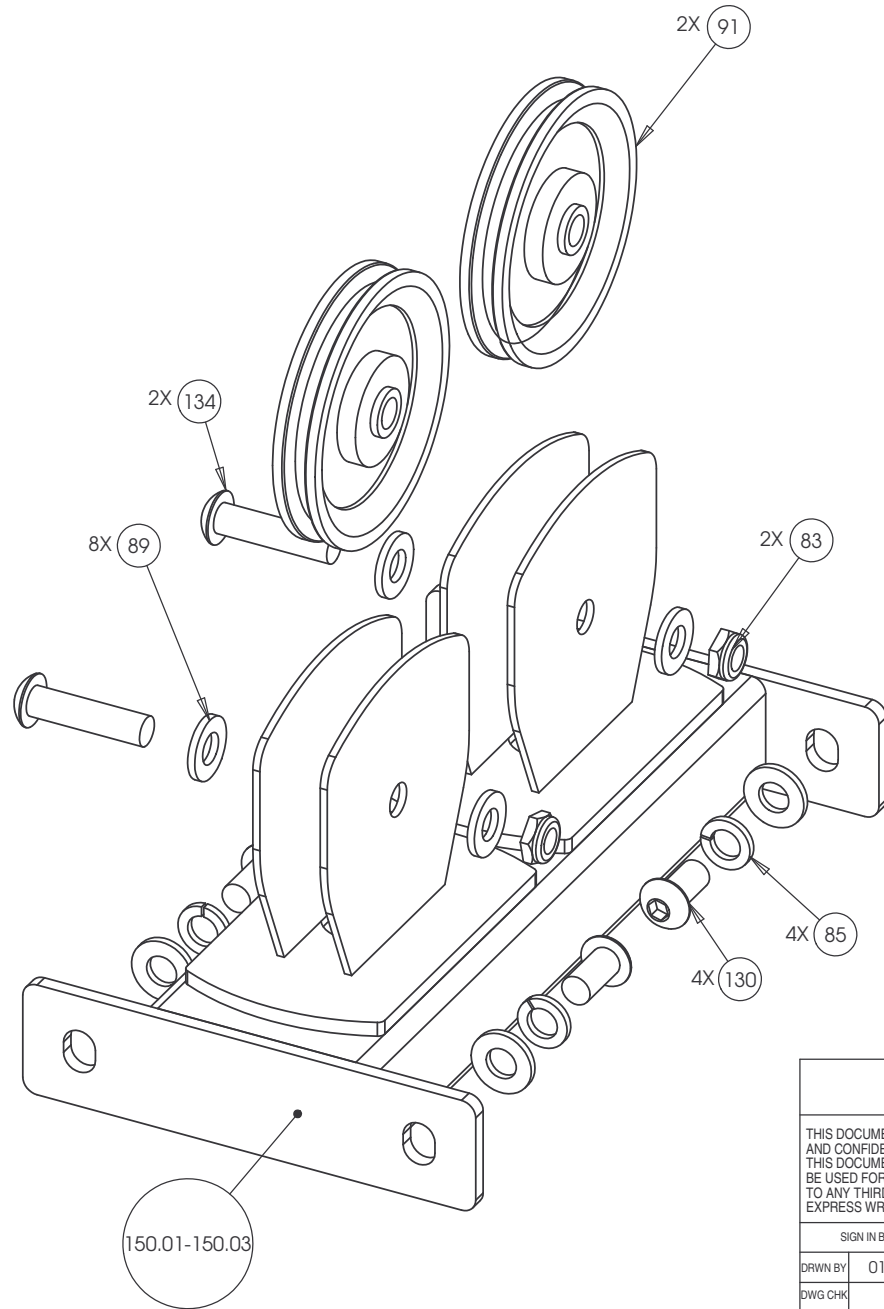

CONFIDENTIAL

THIS DOCUMENT AND INFORMATION CONTAINED HEREIN IS PROPRIETARY AND CONFIDENTIAL TO PRECOR STRENGTH INCORPORATED. RECIPIENTS OF THIS DOCUMENT AGREE THAT THIS DOCUMENT AND INFORMATION WILL NOT BE USED FOR ANY PURPOSE, REPRODUCED OR COPIED, OR DISCLOSED TO ANY THIRD PARTY, EITHER IN WHOLE OR IN PART WITHOUT PRIOR EXPRESS WRITTEN PERMISSION OF PRECOR STRENGTH, INCORPORATED.

PRECOR USA
PRECOR STRENGTH, INC.

28936 AVE WILLIAMS
VALENCIA, CA 91355
TELEPHONE: 661-362-0300

| | | | |
|--------------------------------|----------|---|-----------------------------|
| SIGN IN BLUE OR BLACK INK ONLY | | UNLESS OTHERWISE SPECIFIED: DIMENSIONS ARE IN INCHES | |
| DRWN BY | 01.02.07 | MGP | TOLERANCES ARE: |
| DWG CHK | | | LIN .X=±0.1 .XXX=±0.010 |
| ENG | 01.02.07 | RSG | LIN .XX=±0.02 .XXXX=±0.0001 |
| MFG ENG | | | ANGULAR: ±1.0° |
| CS | | | ALL DIMS AFTER PLATING |
| QA | | | BREAK ALL SHARP EDGES |
| ID | | | REMOVE ALL BURRS |
| REG | | | ALL ANGLES & BENDS 90° |
| | | | DWG PER ASME Y14.5M-1994 |
| | | | DO NOT SCALE DRAWING |
| | | | ALL MACHINED SURFACES |

| | | |
|------|------|----|
| SIZE | PAGE | OF |
| C | 1 | 1 |

| | |
|---|--------|
| PRODUCT: | |
| STRENGTH | |
| ASSEMBLY CONNECTION, 13.75, W/ 2 PULLEY HSG | |
| DWG. NO. | SUBREV |
| CW31876-402 | A |

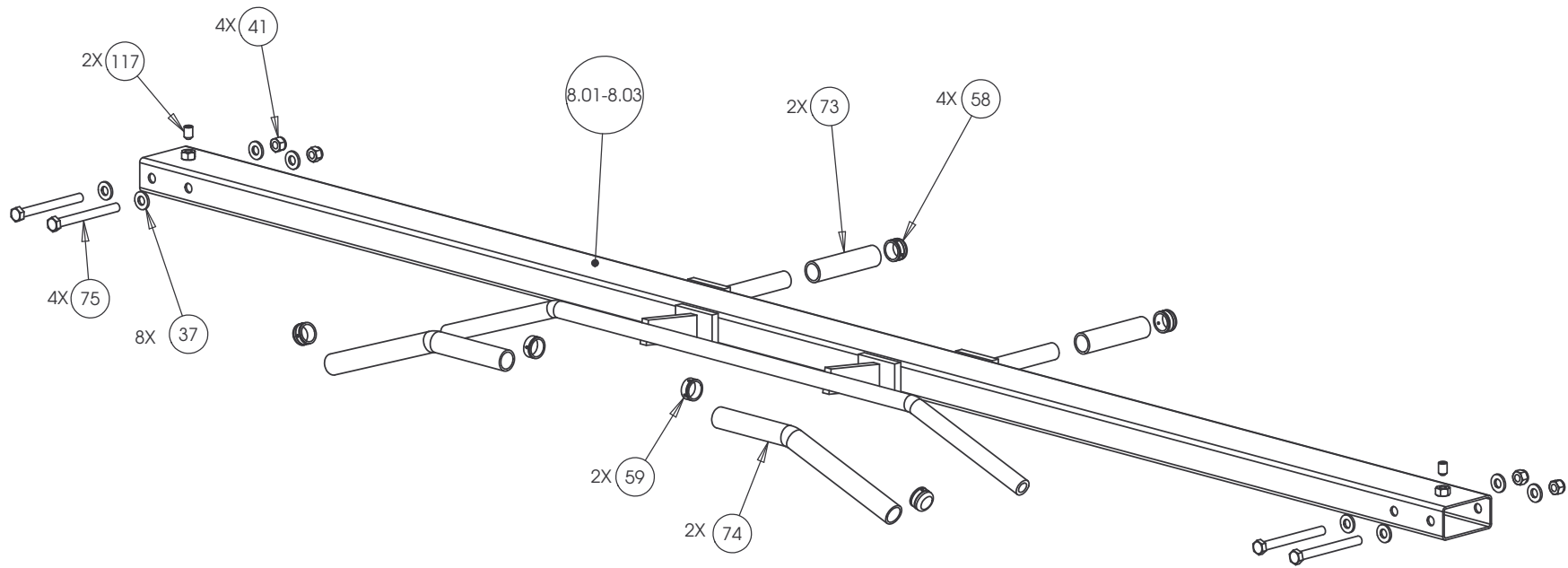

CONFIDENTIAL

THIS DOCUMENT AND INFORMATION CONTAINED HEREIN IS PROPRIETARY AND CONFIDENTIAL TO PRECOR STRENGTH INCORPORATED. RECIPIENTS OF THIS DOCUMENT AGREE THAT THIS DOCUMENT AND INFORMATION WILL NOT BE USED FOR ANY PURPOSE, REPRODUCED OR COPIED, OR DISCLOSED TO ANY THIRD PARTY, EITHER IN WHOLE OR IN PART WITHOUT PRIOR EXPRESS WRITTEN PERMISSION OF PRECOR STRENGTH, INCORPORATED.

PRECOR USA
PRECOR STRENGTH, INC.

28936 AVE WILLIAMS
VALENCIA, CA 91355
TELEPHONE: 661-362-0300

| SIGN IN BLUE OR BLACK INK ONLY | | | UNLESS OTHERWISE SPECIFIED: DIMENSIONS ARE IN INCHES | | | PRODUCT: | |
|--------------------------------|----------|-----|---|-----------|---------------|---|--------|
| DRWN BY | 01.02.07 | MGP | TOLERANCES ARE: | | | STRENGTH | |
| DWG CHK | | | LIN | .X=±0.1 | .XXX=±0.010 | ASSEMBLY CONNECTION, 107 IN, CROSSBEAM W-HANDLES | |
| ENG | 01.02.07 | RSG | LIN | .XX=±0.02 | .XXXX=±0.0001 | | |
| MFG ENG | | | ANGULAR: ±1.0° | | | | |
| CS | | | ALL DIMS AFTER PLATING | | | | |
| QA | | | BREAK ALL SHARP EDGES | | | | |
| ID | | | REMOVE ALL BURRS | | | | |
| REG | | | ALL ANGLES & BENDS 90° | | | DWG. NO. | SUBREV |
| | | | DWG PER ASME Y14.5M-1994 | | | CW31878-401 | A |
| | | | DO NOT SCALE DRAWING | | | | |
| | | | ALL MACHINED SURFACES | | | | |
| | | | C | 1 | 1 | | |

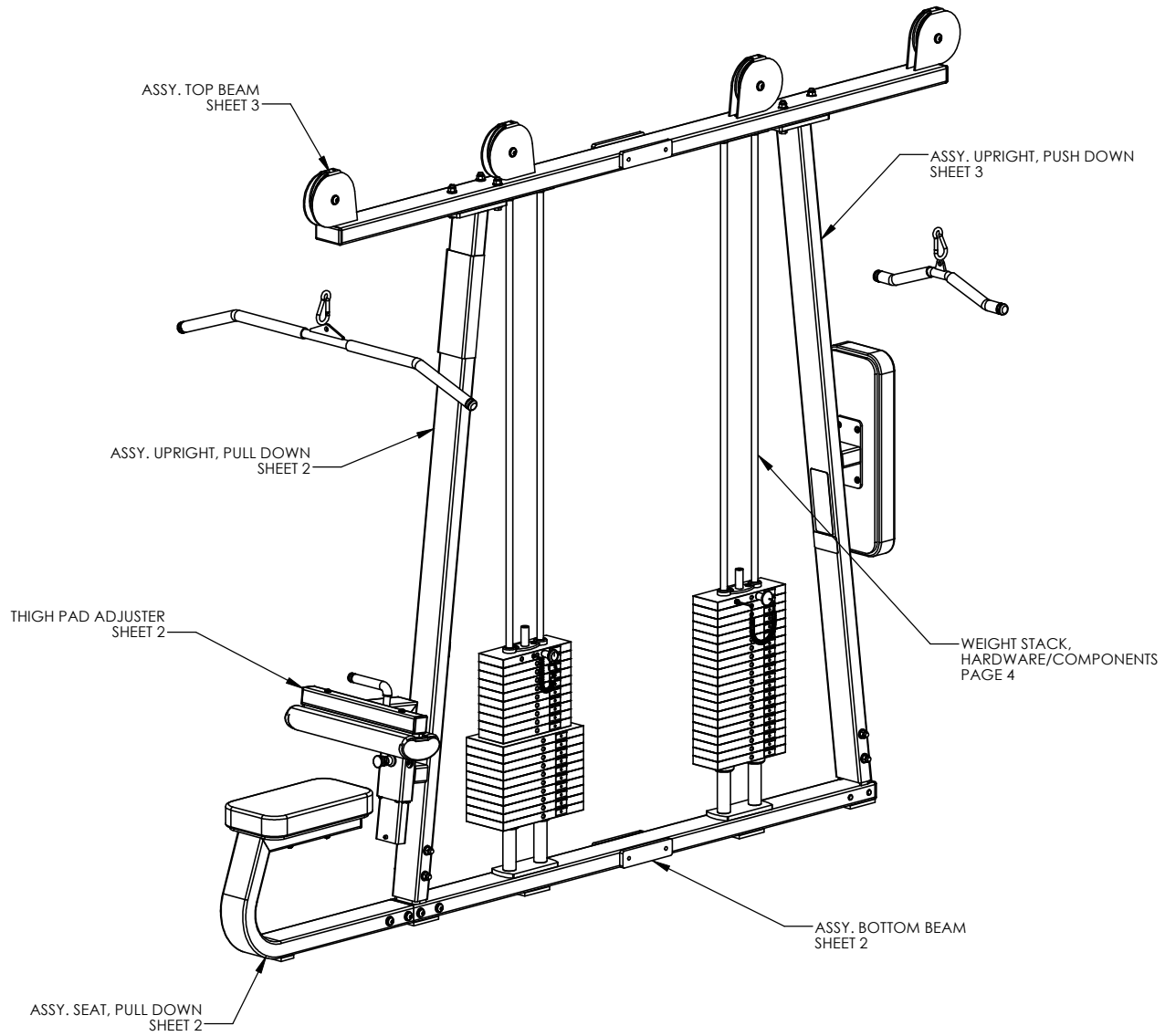

| | |
|------------------|----------------|
| P/N: CW31927-402 | SUBREV: E |
| DRAWN BY: VLE | DATE: 08.18.09 |
| SHEET 1 OF 4 | |

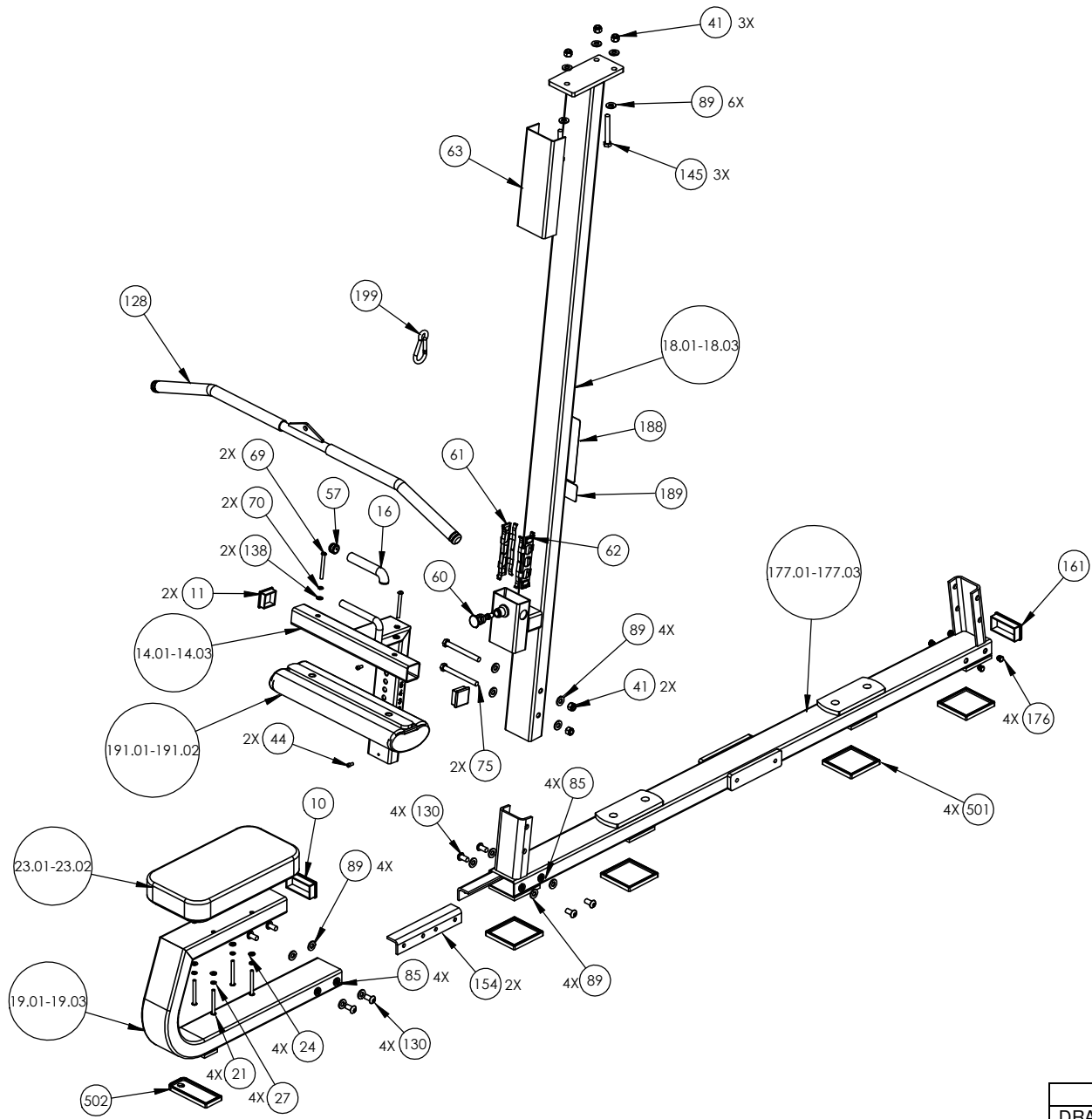

| | |
|------------------|----------------|
| P/N: CW31927-402 | SUBREV: E |
| DRAWN BY: VLE | DATE: 08.18.09 |
| SHEET 2 OF 4 | |

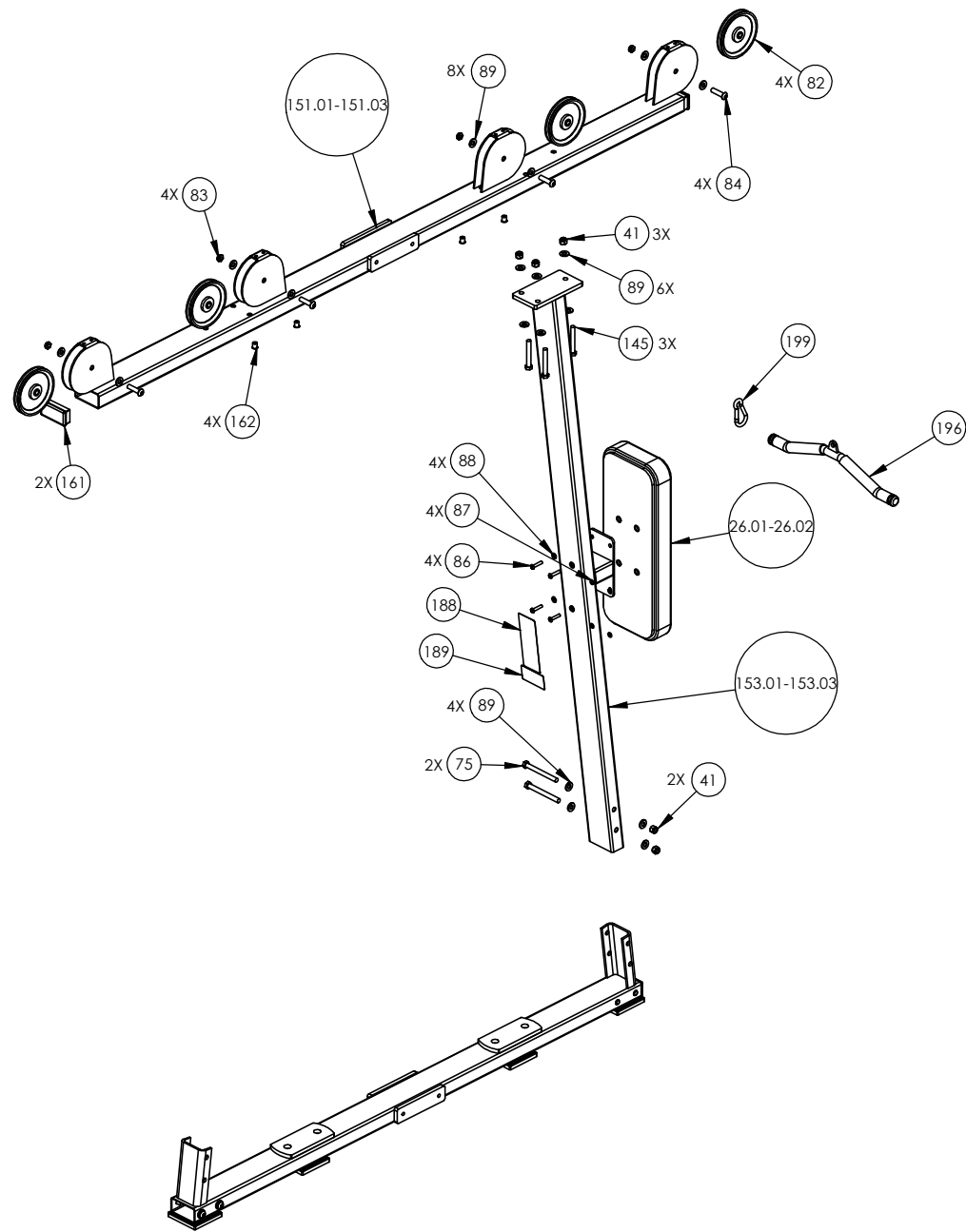

| | |
|------------------|----------------|
| P/N: CW31927-402 | SUBREV: E |
| DRAWN BY: VLE | DATE: 08.18.09 |
| SHEET 3 OF 4 | |

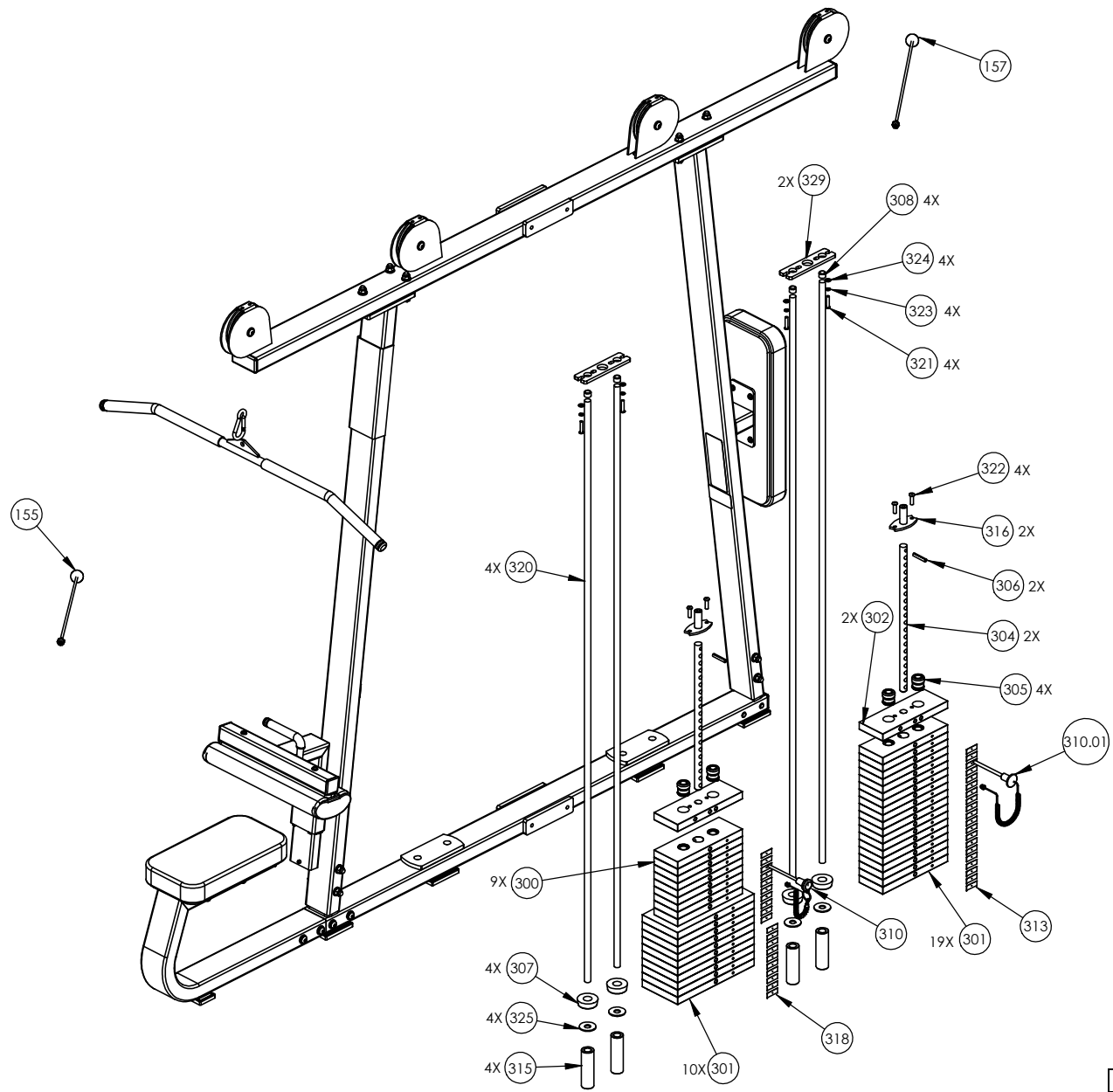

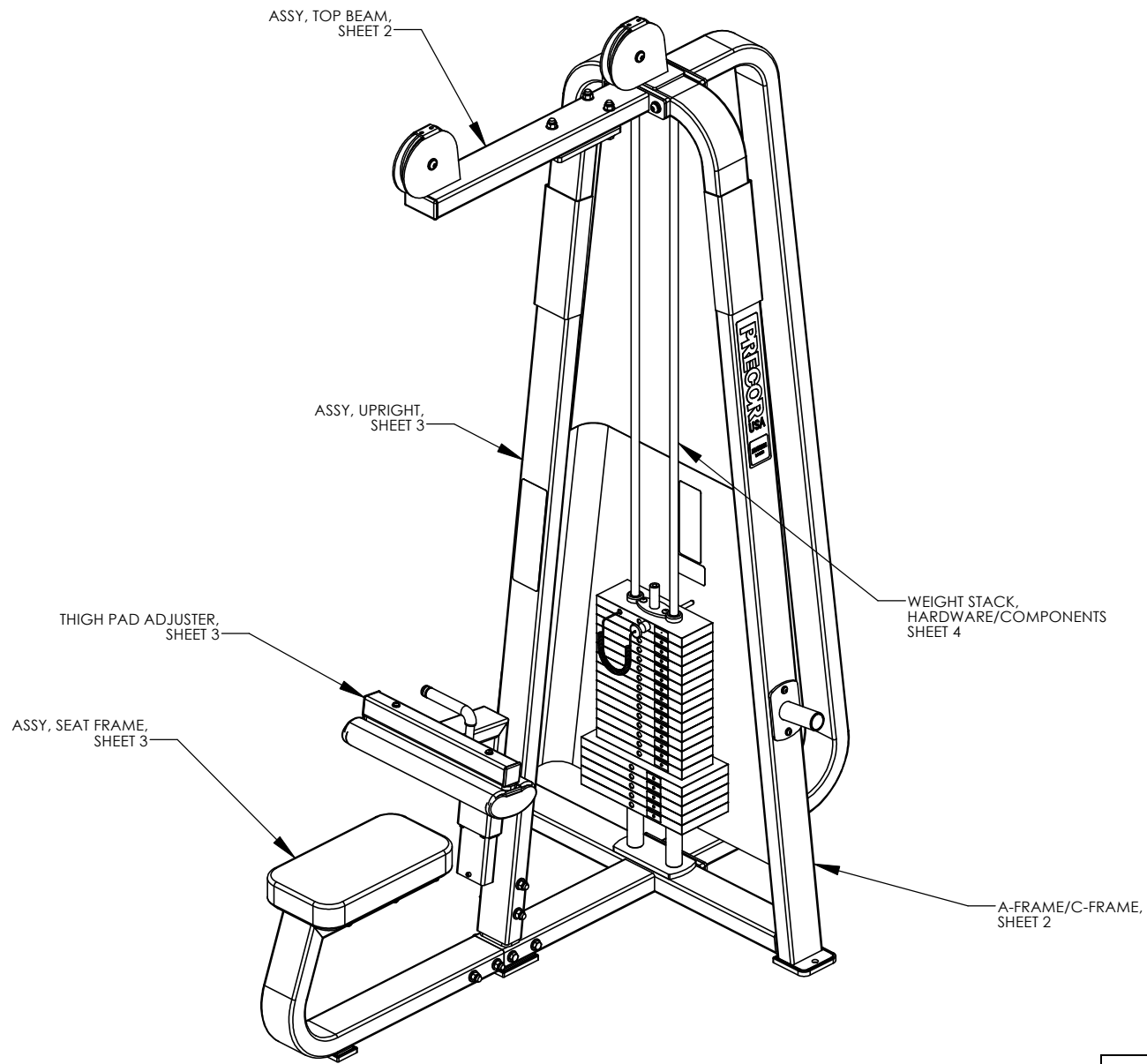

| | |
|------------------|----------------|
| P/N: CW31932-402 | SUBREV: C |
| DRAWN BY: JEC | DATE: 09.11.08 |
| SHEET 1 OF 4 | |

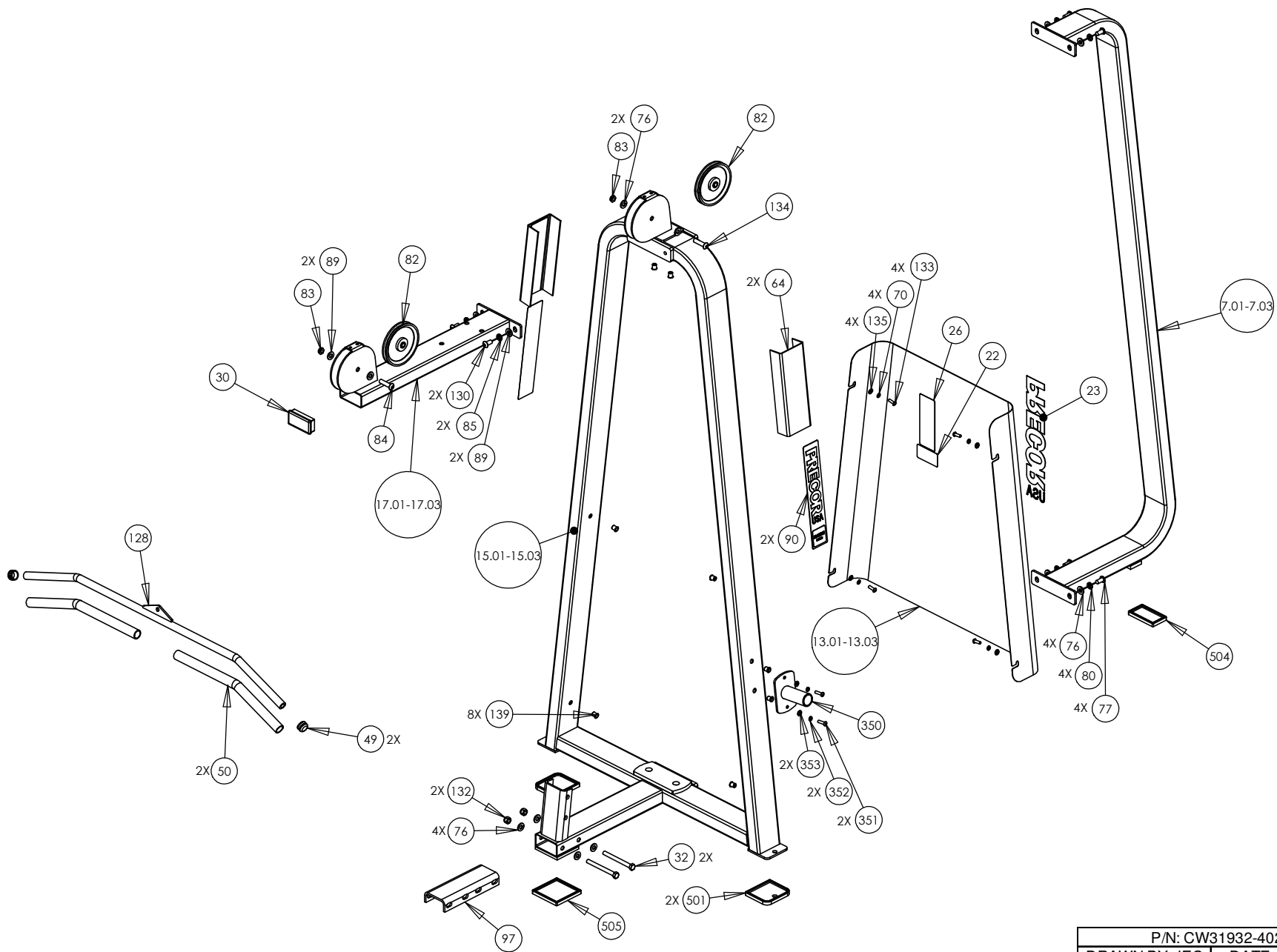

| | |
|------------------|----------------|
| P/N: CW31932-402 | SUBREV: C |
| DRAWN BY: JEC | DATE: 09.11.08 |
| SHEET 2 OF 4 | |

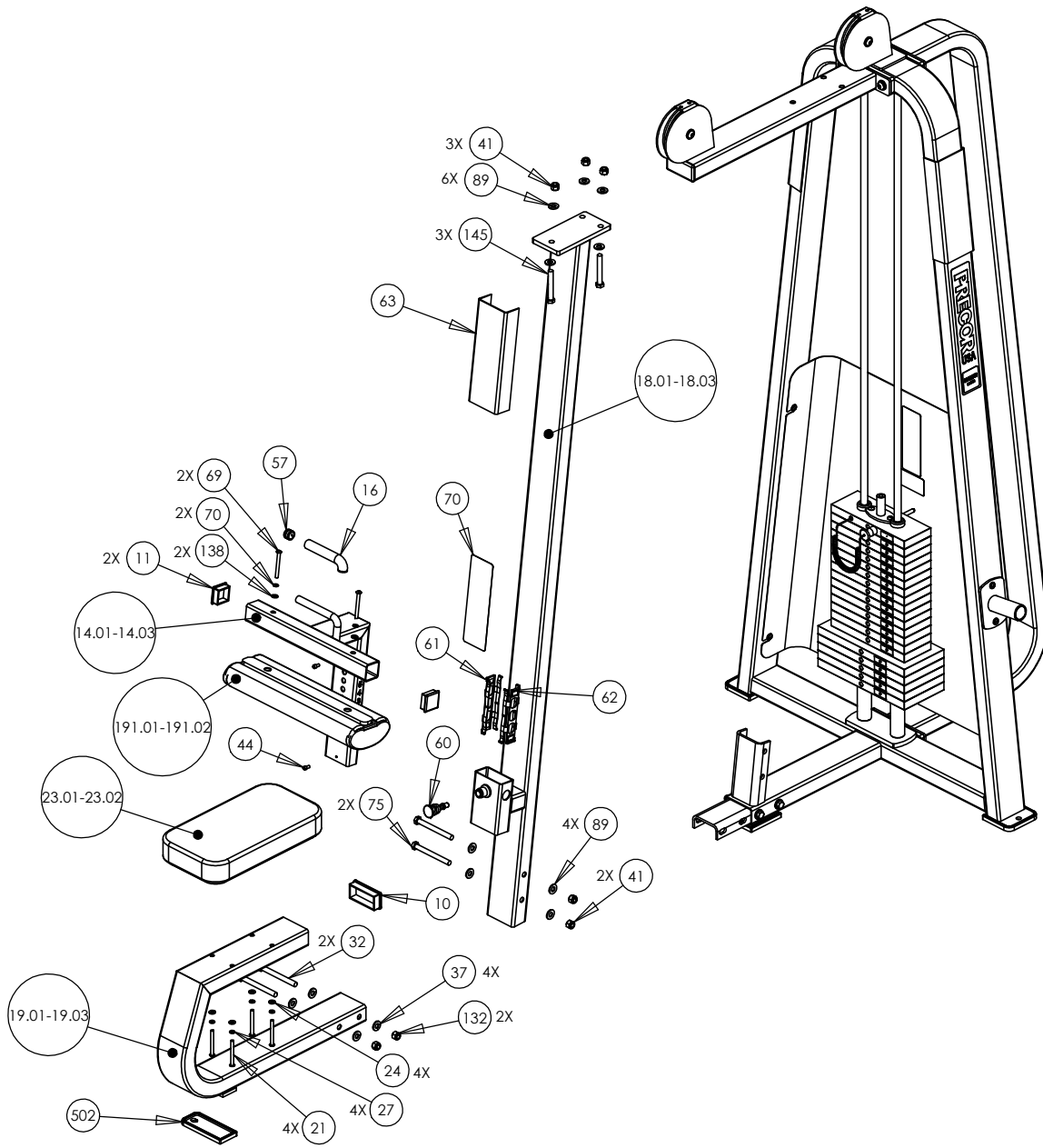

| | |
|------------------|----------------|
| P/N: CW31932-402 | SUBREV: C |
| DRAWN BY: JEC | DATE: 09.11.08 |
| SHEET 3 OF 4 | |

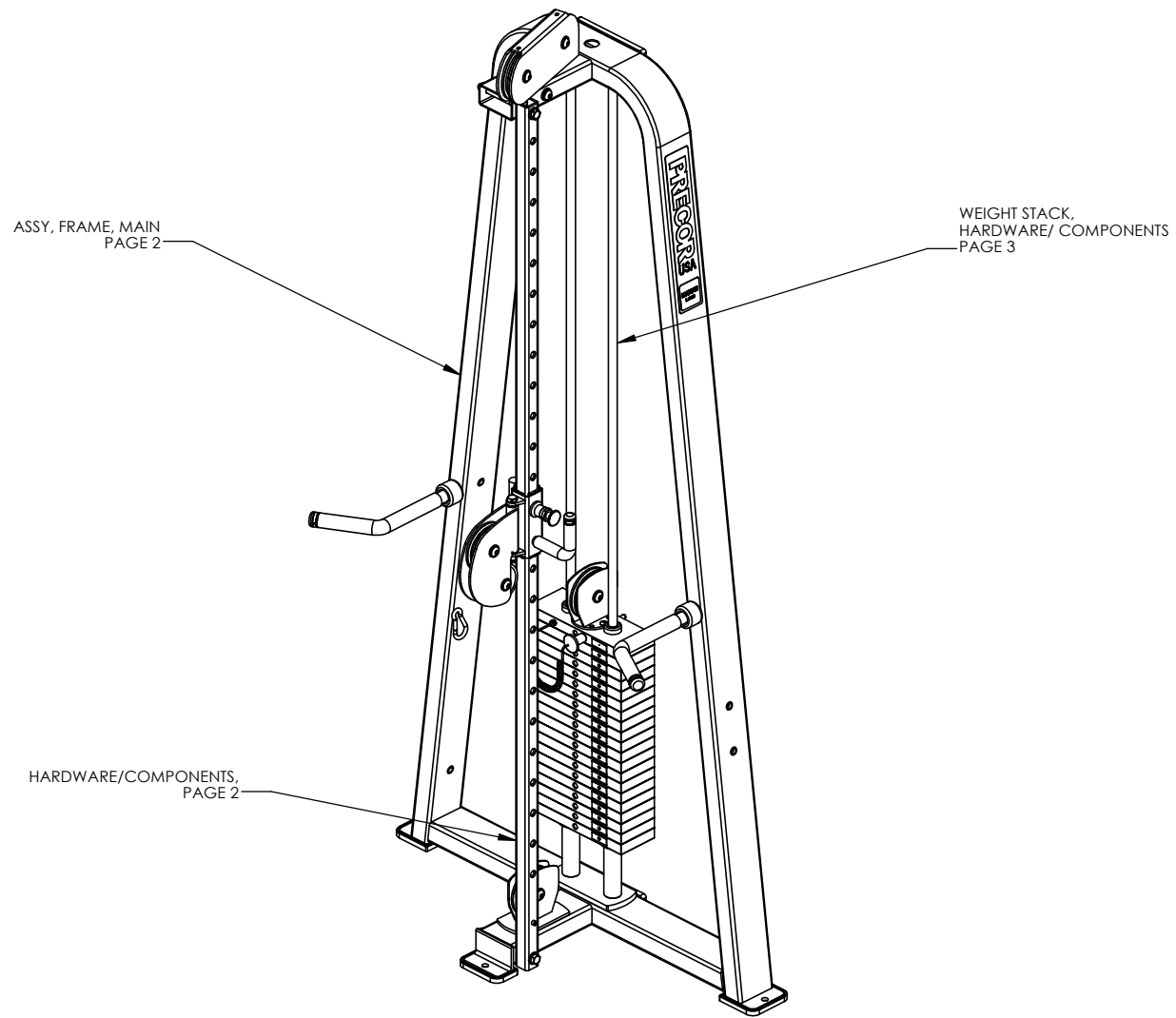

| | |
|------------------|----------------|
| P/N: CW34920-401 | SUBREV: A |
| DRAWN BY: VLE | DATE: 06.24.09 |
| SHEET 1 OF 3 | |

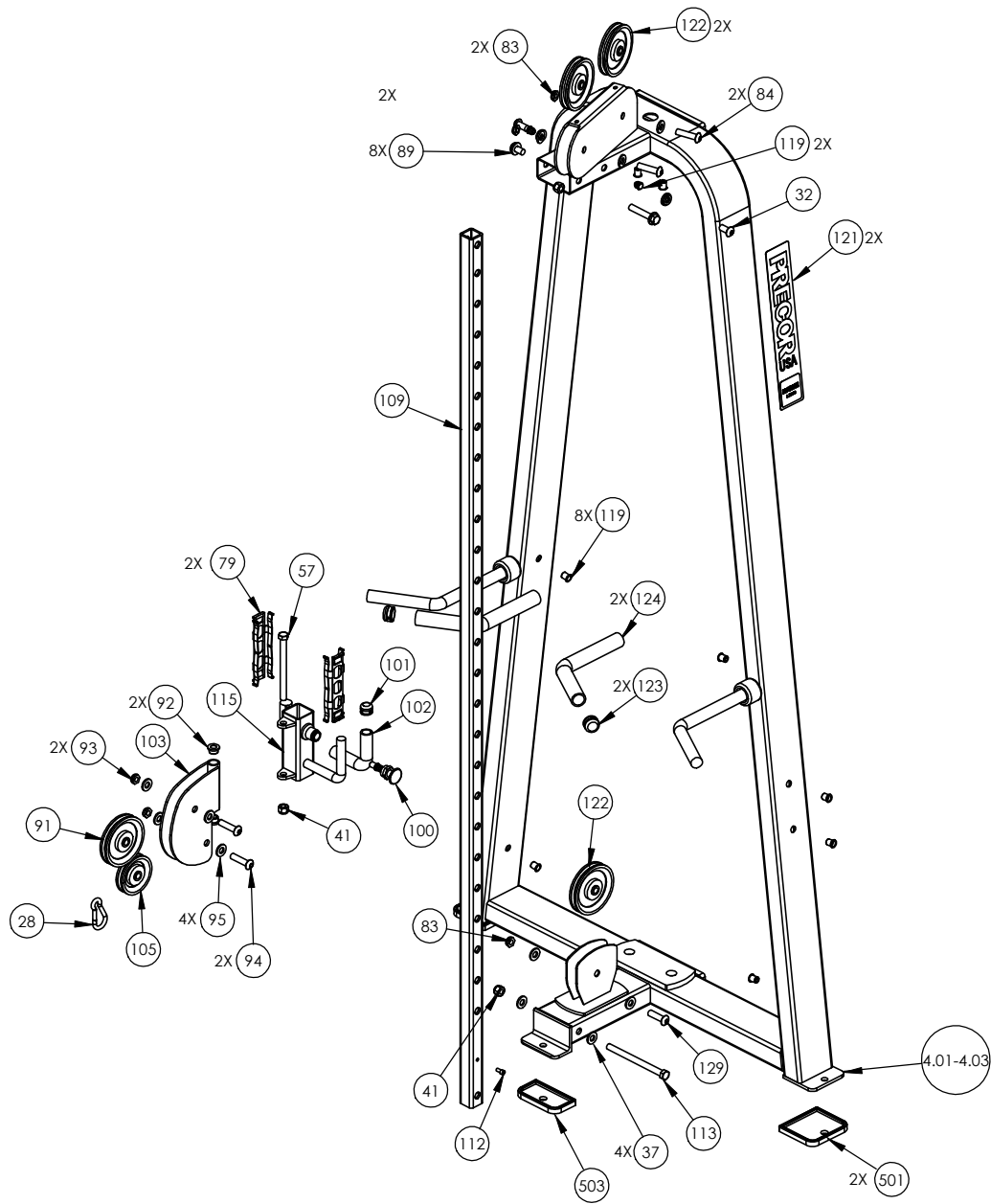

| | | |
|------------------|----------------|--------------|
| P/N: CW34920-401 | | SUBREV: A |
| DRAWN BY: VLE | DATE: 06.24.09 | SHEET 2 OF 3 |

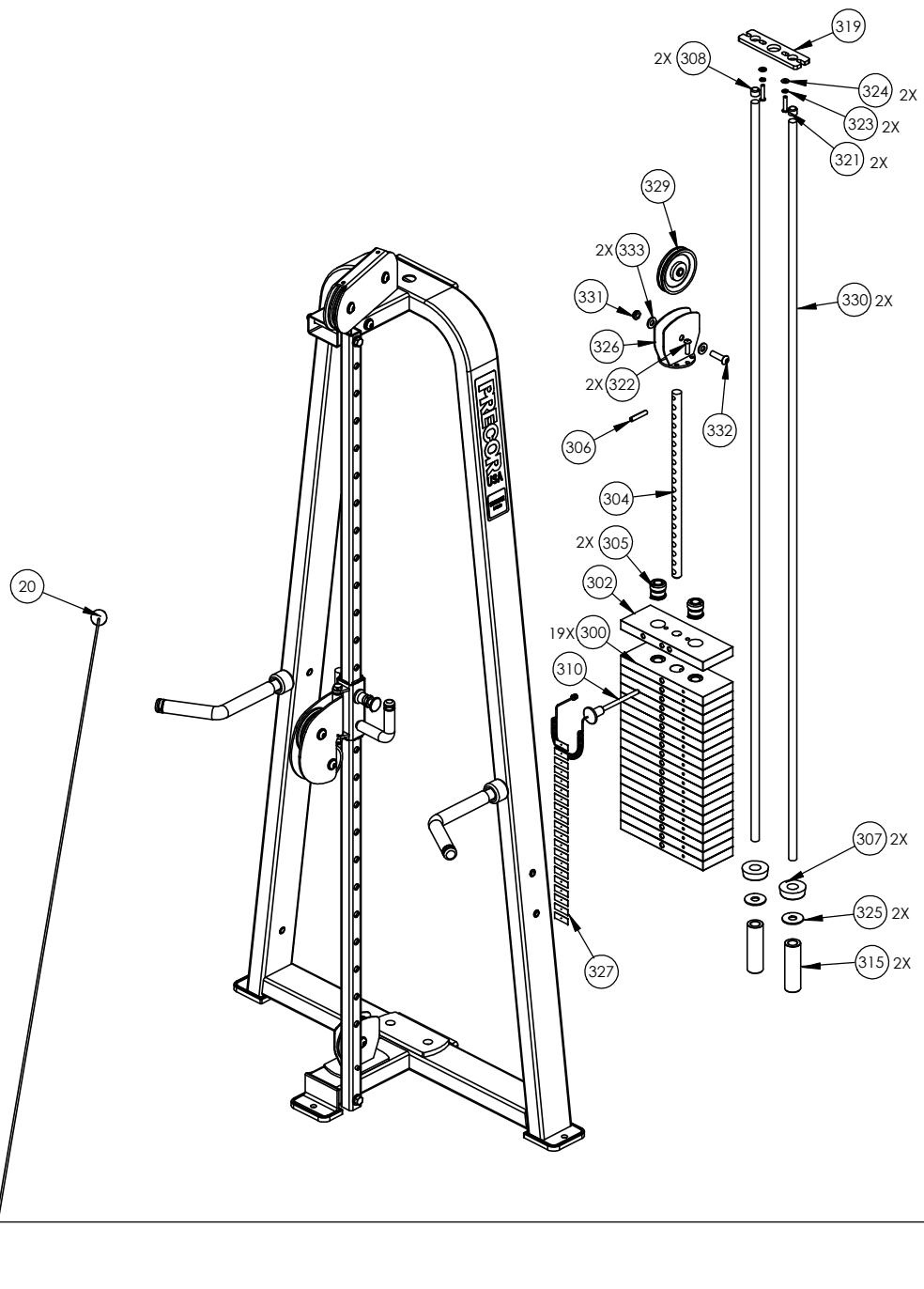

| | |
|------------------|----------------|
| P/N: CW34920-401 | SUBREV: A |
| DRAWN BY: VLE | DATE: 06.24.09 |
| SHEET 3 OF 3 | |

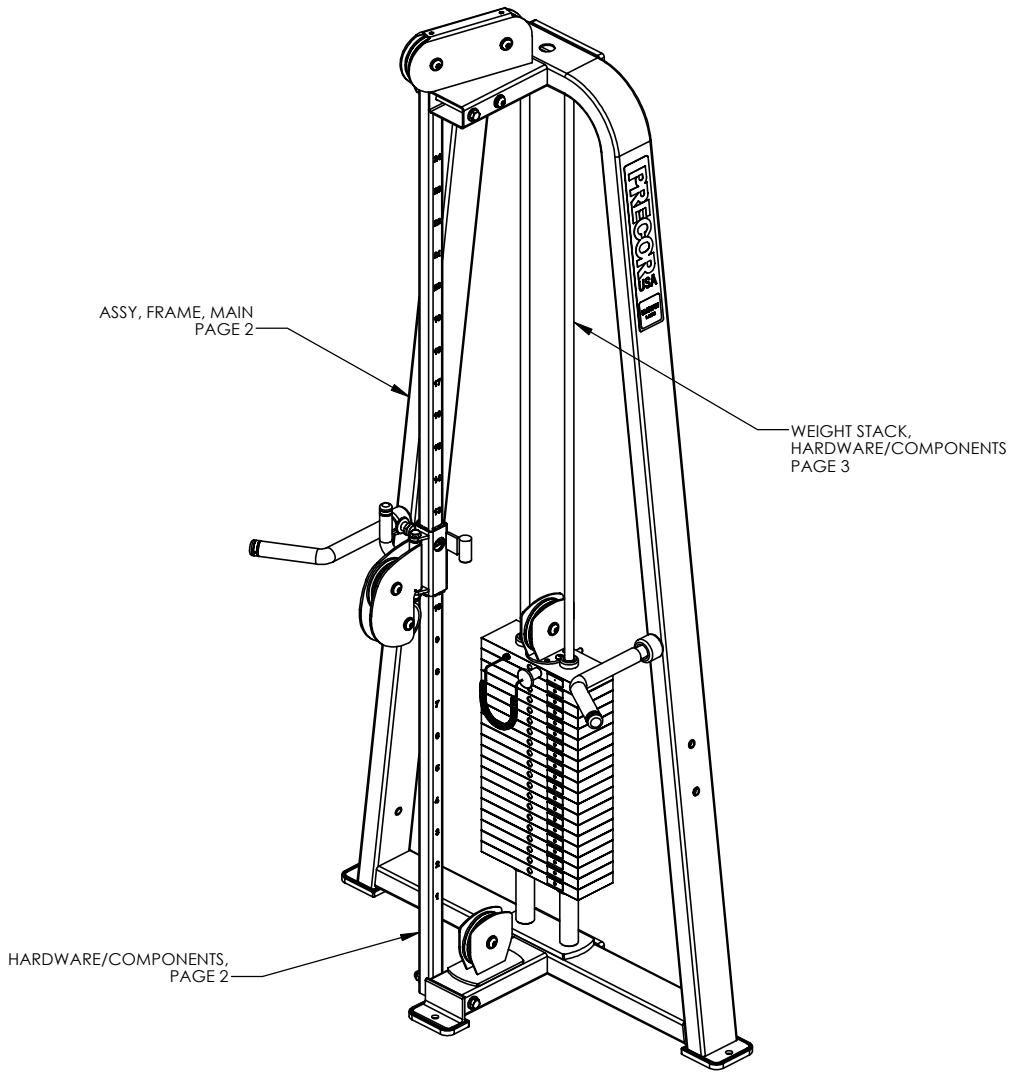

| | |
|------------------|----------------|
| P/N: CW34921-401 | SUBREV: A |
| DRAWN BY: VLE | DATE: 06.24.09 |
| SHEET 1 OF 3 | |

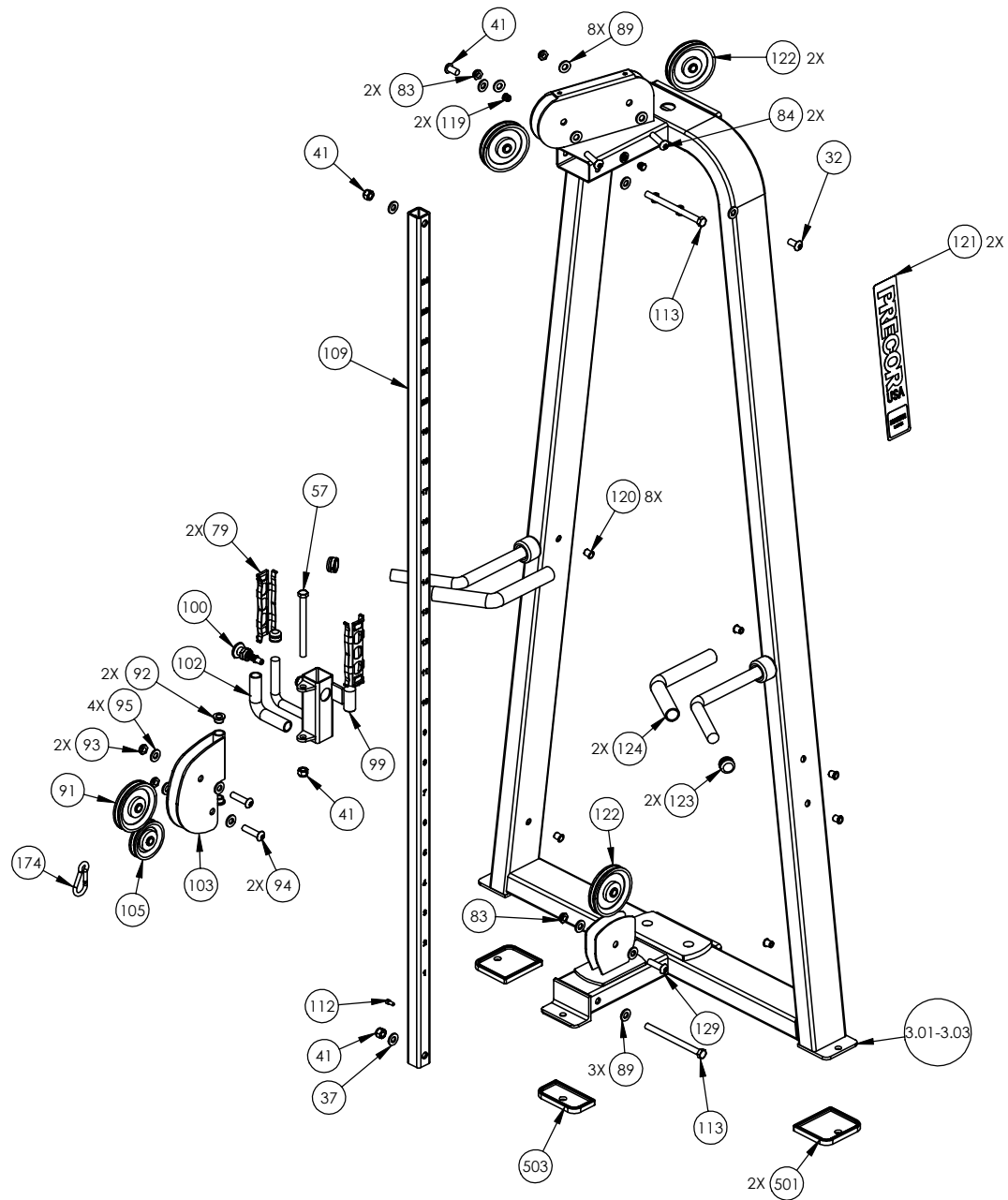

| | |
|------------------|----------------|
| P/N: CW34921-401 | SUBREV: A |
| DRAWN BY: VLE | DATE: 06.24.09 |
| SHEET 2 OF 3 | |

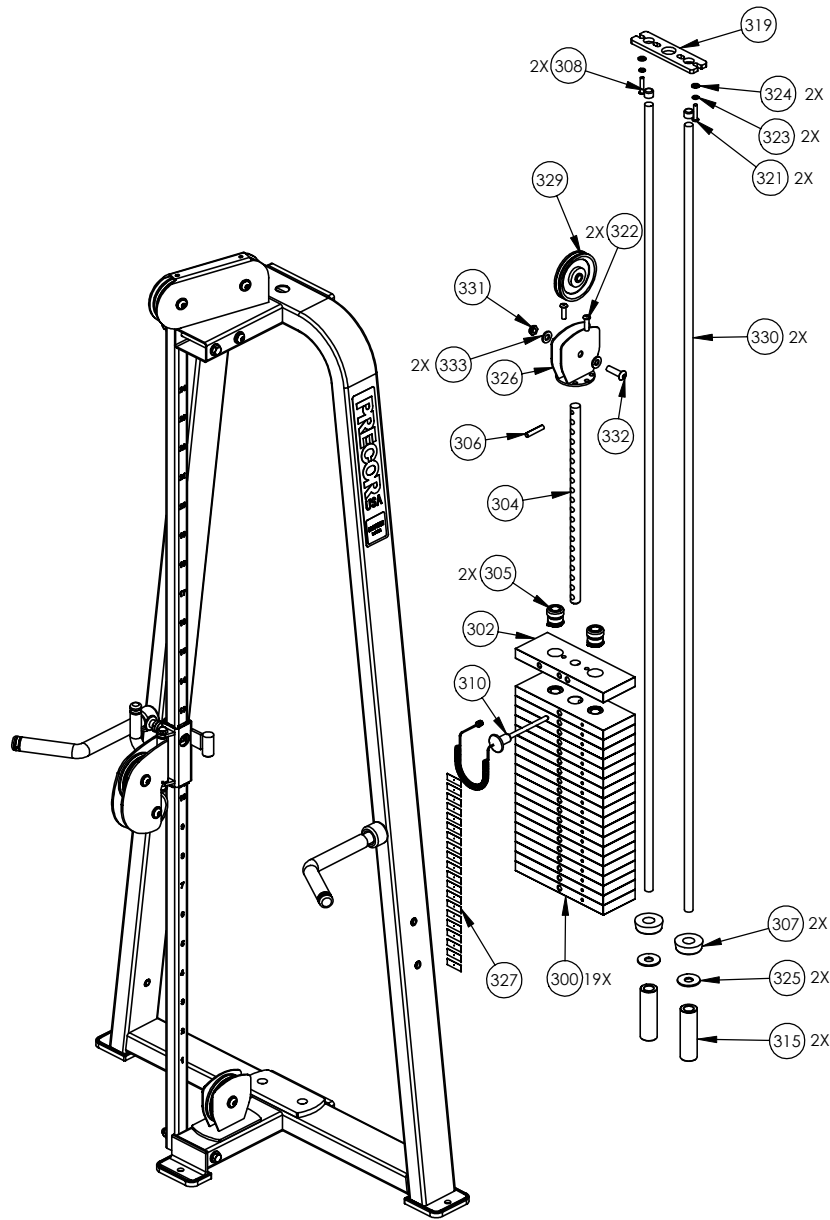

| | |
|------------------|----------------|
| P/N: CW34921-401 | SUBREV: A |
| DRAWN BY: VLE | DATE: 06.24.09 |
| SHEET 3 OF 3 | |

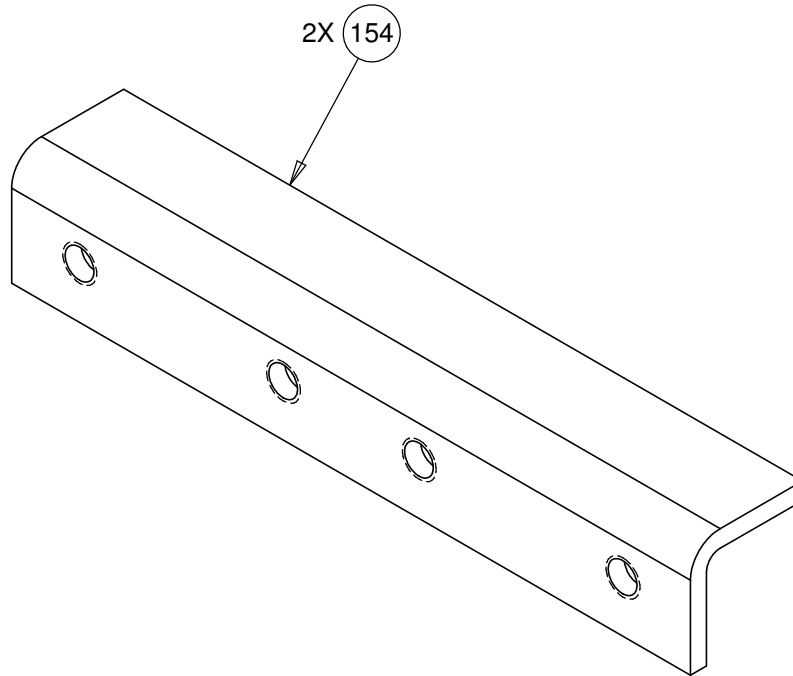

CONFIDENTIAL

THIS DOCUMENT AND INFORMATION CONTAINED HEREIN IS PROPRIETARY AND CONFIDENTIAL TO PRECOR STRENGTH INCORPORATED. RECIPIENTS OF THIS DOCUMENT AGREE THAT THIS DOCUMENT AND INFORMATION WILL NOT BE USED FOR ANY PURPOSE, REPRODUCED OR COPIED, OR DISCLOSED TO ANY THIRD PARTY, EITHER IN WHOLE OR IN PART WITHOUT PRIOR EXPRESS WRITTEN PERMISSION OF PRECOR STRENGTH INCORPORATED.

PRECOR USA
PRECOR STRENGTH, INC.

**28936 AVE WILLIAMS
VALENCIA, CA 91355
TELEPHONE: 661-362-0300**

| | | | | | |
|--------------------------------|----------|-----|--|-----------|---------------|
| SIGN IN BLUE OR BLACK INK ONLY | | | UNLESS OTHERWISE SPECIFIED: DIMENSIONS ARE IN INCHES TOLERANCES ARE: | | |
| DRWN BY | 08.27.09 | VLE | LIN | .X=±0.1 | .XXX=±0.010 |
| DWG CHK | | | LIN | .XX=±0.02 | .XXXX=±0.0001 |
| ENG | 08.27.09 | VLE | ANGULAR: ±1.0° | | |
| MFG ENG | | | ALL DIMS AFTER PLATING | | |
| CS | | | BREAK ALL SHARP EDGES | | |
| QA | | | REMOVE ALL BURRS | | |
| ID | | | ALL ANGLES & BENDS 90° | | |
| REG | | | DWG PER ASME Y14.5M-1994 | | |
| | | | DO NOT SCALE DRAWING | | |
| | | | 125° ALL MACHINED SURFACES | | |
| | | | SIZE | PAGE | OF |
| | | | A | 1 | 1 |

PRODUCT:
STRENGTH

STEEL, CHANNEL

DWG. NO. **CW33293-402** SUBREV **A**